

# Armak Geared Piston Air Motor

## Type AGP04B



### New Technology Air Motors

- non vibrating operation even at high speeds
- contact free rotating pistons, resulting in long lifetime with reduced maintenance
- motor efficiency increases over time
- completely enclosed motor casing prevents internal corrosion. Without an internal oil sump
- compact design with total freedom of installation
- usable speed range from 75 rpm - high start torque
- metric flange D080 for mounting of standard IEC gear boxes. SAE flange upon request
- motor shaft AGP04BE with key and keyway
- perfect control with Armak lever / remote control valves. including emergency stop or brake to machinery directive
- ATEX II cat. 2 GDcT5 and ATEX I M2 can be supplied, valid under ATEX operating parameters



The torque is developed by one power piston and is transferred to the output shaft with a second also contact free rotating piston by a synchronising gear train. This frictionless operation results in a long **maintenance free operation** without downtime. The **totally closed motor housing** without breather holes permits applications in wet or dirty surroundings without corrosion inside the motor

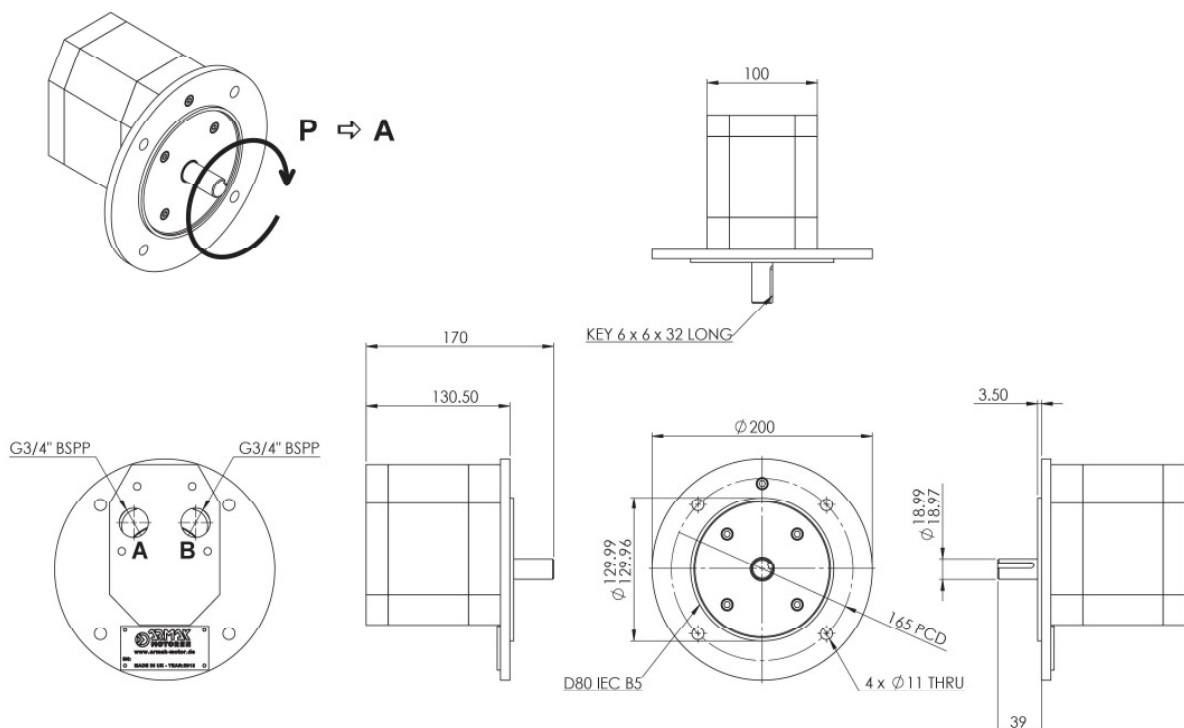

# Armak Geared Piston Air Motor

## Type AGP04B



### Technical Data for Motor AGP04FA at 6bar

valid for motor AGP04BE without accessories like silencer, FRL, valves etc

Motor	AGP04BE		AGP04BE		
Max. Power at 6 bar	kW	3.5	Air lubrication short run	drop/min	12 – 16
Speed at max. power and 6 bar	rpm	2.200	Air lubrication continuous run	drop/min	6 – 8
Torque at max power and 6 bar	Nm	15	Operating temperature range	° C	-20 - +80
Starting torque at 6 bar	Nm	17	max. inlet air temperature	° C	+65
max. continuous speed	rpm	2.200	Mass	kg	12
suggested min. speed	rpm	75	Radial force middle of shaft	N	2.000
Air line connection	G 3/4"		Axial force on shaft	N	20

Motor Versions	Part Number
Motor basic design	AGP04BE
Motor with lever control valve LCV - biased CW	AGP04BJ
Motor with lever control valve LCV - biased ACW	AGP04BK
Motor with lever control valve LCV - no bias	AGP04BL
Motor with remote control valve RCV - no bias	AGP04BR
Motor with remote control valve RCV - biased CW	AGP04BV
Motor with remote control valve RCV - biased ACW	AGP04BW
Accessories	part number
Remote control	on request
Brake	on request
Gear box	on request
Silencer	on request
Service kit	on request
Filter / regulator / lubricator	on request

**ATEX II Kat. 2 GDC T5** and **ATEX I M2** can be supplied, but for ATEX I M2 only if short time motor speed does not exceed 1.800 rpm, motor air inlet temperature does not exceed 50°C, ambient temperature does not exceed 50°C, air inlet pressure does not exceed 4.5 bar, filtration is better than 45 µ

# Armak Geared Piston Air Motor

## Type AGP04B



### Valves:

In winch operation a lowering load can be braked to a full stop using Armak Valves. A parking brake can be used instead of a dynamic brake which requires frequent service.

### Note:

All data are valid only with sufficient air supply and when using correctly sized fittings and valves with net. cross section suitable for the air volume required. Pressure loss by lubricator, silencer, valves and piping must be considered.

From the operating point consider the starting torque (example winches) or consider the operating torque (example pump drive).

In case of system failure (blocked shaft) the max. starting torque must be considered to prevent the motor from damaging gears or other components.

When using gears consider the gearbox efficiency: helical / epicyclic gears up to 97% per stage, worm gears sometimes below 50%, all depending on gear box design.

### Additional Armak Motors:

Armak Geared Piston Air Motor AGP01, AGP06, AGP07, AGP10, AGP16

Armak Gas Pressure Motor GGP04, GGP16

### Final Comment

In order to assure long and trouble free operation above data and additional data from the service manual must be adhered to.

### Performance Data for AGP04B

valid for 6 bar pressure difference across the motor

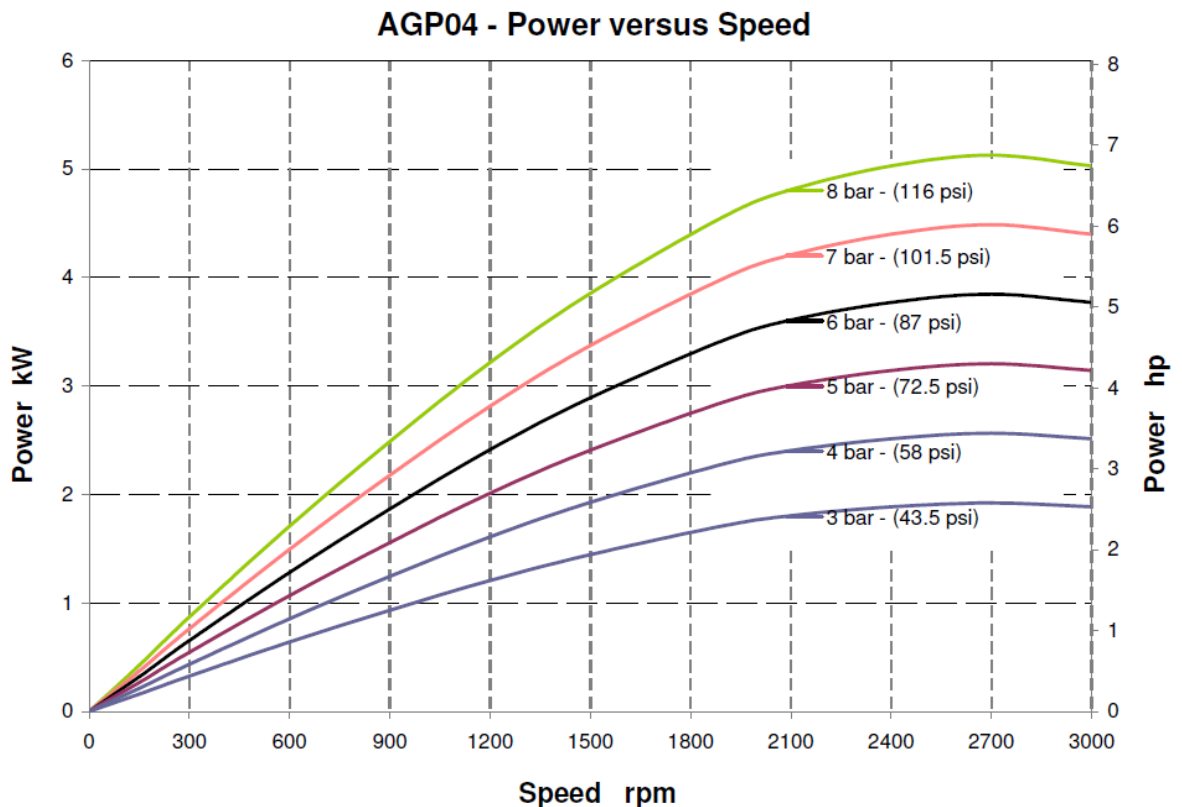

**AGP04 Torque versus Speed**

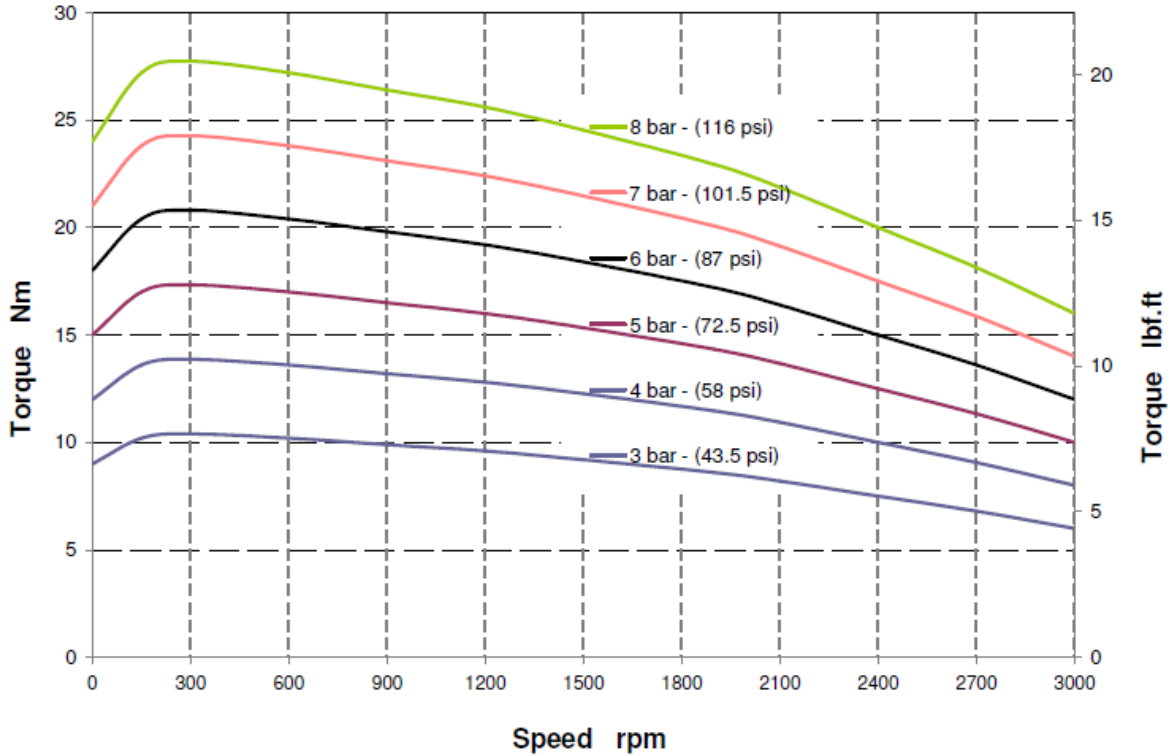

**AGP04 Air Consumption versus Speed**

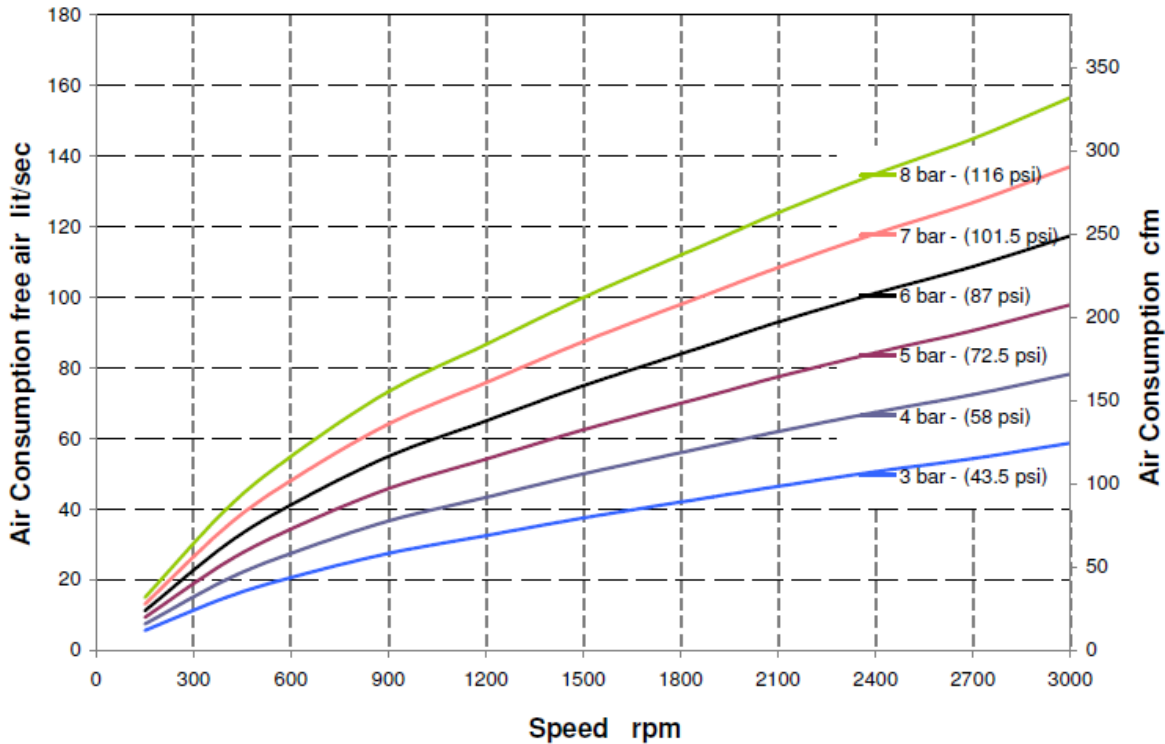

# Armak Geared Piston Air Motor Type AGP04B



## Armak Motor AGP04J, AGP04K or AGP04L with Lever Control Valve

To prevent operator errors, the valve installation must fit the actual application.

On all motors AGP04, AGP07, AGP10 or AGP16 the control lever can point upwards, forward or down.

Such lever adjustment can be done even during the final installation of the motor

To achieve bias in valves as required for example in winch applications, CP check plates are installed in the valves. Depending on the application and on the users equipment, the air flow cross section in these check plates must adjusted.

Armak Lever Control or Remote Control Valves can completely if briefly stop the lowering under load on a winch. Brakes therefore will be static brakes with long life.

On Armak Air Motors AGP16 (shown below) the power valve can be mounted to the right or left of the motor. The power valve position must be specified with order.

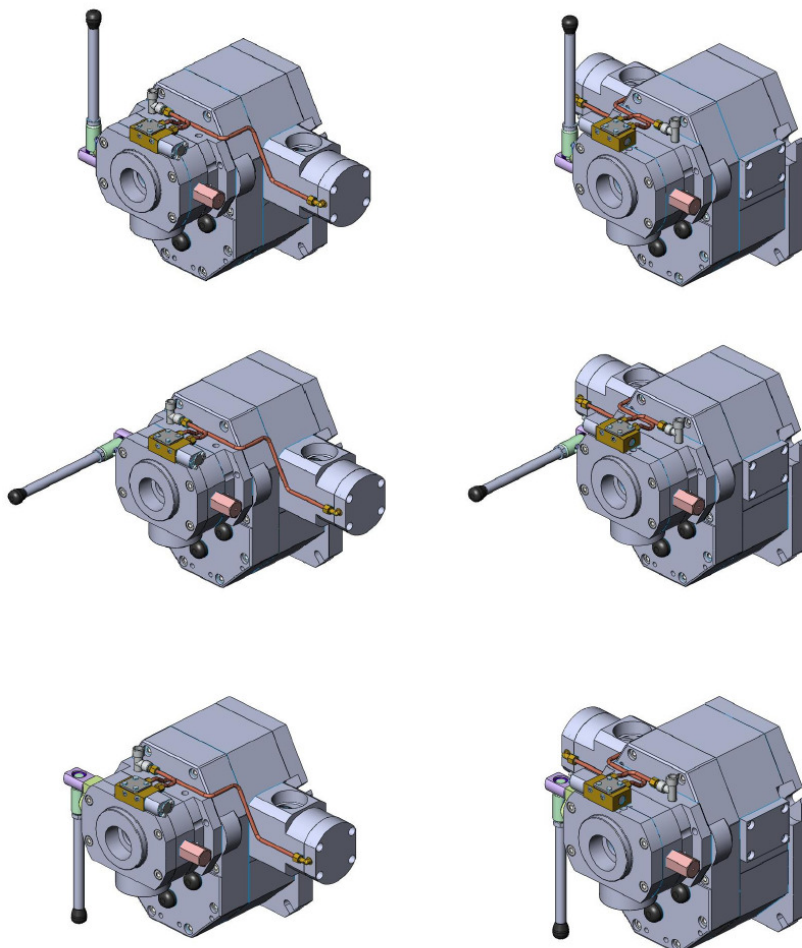



# Armak Geared Piston Air Motor Type AGP04B



Motor	Data at max. power and 6 bar			Start Torque Nm	max. continuous rpm	Mass kg
	kW	rpm	Nm			
AGP01	1,8	2.700	6.6	6.3	3.000	9
AGP110◆	1,8	2.700	6.6	6.3	3.000	9
RM110	1.2	2.100	5,3	6,8 – max. 11	2.400	13
AGP04	3,5	2.200	15	17	2.500	14
AGP210◆	3,5	2.200	15	17	2.500	14
RM210	2.8	1.980	14	19 – max 35	2.400	26
AGP06	6,2	2.600	22	28	2.600	20
AGP07	8,0	1.600	50	90	2.000	60
AGP310◆	8,0	1.600	50	90	2.000	60
RM310	6.1	1.800	32	35 – max 70	2.400	48
AGP10	11,0	1.100	95	140	1.800	75
AGP410◆	11,0	1.100	95	140	1.800	75
RM410	10,5	1.600	62	75 – max. 70	2.000	62
AGP16	16,0	1.300	120	165	1.800	82
AGP510◆	16.0	1.300	120	165	1.800	82
RM510	16.0	1.150	132	170–max 240	1.500	115

◆ AGP Motor with flange identical to equivalent Globe Radial Piston Motor

Winch Drive



Coal Mining Locomotive



Earth Drilling Rig



Production Facility Hull, England

## Armak Geared Piston Motors GP

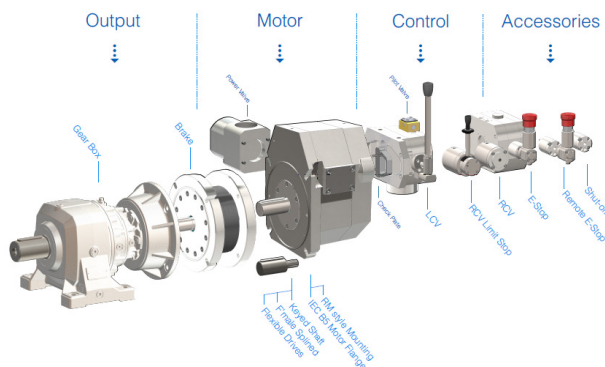

We reserve the right for improvements without prior notice

**Armak GmbH - Motoren**  
 Enzstr.39 D-70806 Kornwestheim  
 Geschäftsführer Wolf Krisch  
 Blatt 6 von 6

Fon +49 7154 82400  
 Fax +49 7154 824080  
 HRB 207012 Stuttgart

www.armac-motor.de  
 info@armac-motor.de  
 ID-Nr DE814130032  
 a6204 -AGP04BE-1638